

Please cite the published version of this paper:

Teh, S.H., Wiedmann, T., (2018) Decomposition of integrated hybrid life cycle inventories by origin and final-stage inputs. *Journal of Economic Structures*, 7(1), 15. doi: <https://doi.org/10.1186/s40008-018-0115-1>



Water
Research
Centre



SUSTAINABILITY
ASSESSMENT PROGRAM

SAP Working Paper January 2018

Note on the Decomposition of integrated hybrid life cycle inventories by industry, product and process

Soo Huey Teh^{a,*} and Thomas Wiedmann^{a,b}

^{a.} Sustainability Assessment Program (SAP), School of Civil and Environmental Engineering, UNSW Sydney, NSW 2052, Australia

^{b.} Integrated Sustainability Analysis (ISA), School of Physics A28, The University of Sydney, NSW 2006, Australia

* Corresponding author. Email: soohuey.teh@unsw.edu.au

Abstract

This note presents a method to decompose life cycle inventories derived from integrated and mixed-unit hybrid life cycle assessment. The approach extends the decomposition method described by [Wiedmann \(2017\)](#) by differentiating between impacts from industries, products and processes. The method can be used to quantify the cradle-to-sale impacts of products and processes in the final stage of manufacturing a particular product. We present such a decomposition for the example of life-cycle inventories for different types of concrete and compare it to one where the life cycle inventories have been decomposed by origin.

Keywords

Decomposition, Total impact multipliers, Life cycle inventories, Hybrid life cycle assessment, Integrated hybrid LCA, Mixed-unit hybrid LCA, Concrete, Origin, Final-stage inputs

Please cite the published version of this paper:

Teh, S.H., Wiedmann, T., (2018) Decomposition of integrated hybrid life cycle inventories by origin and final-stage inputs. *Journal of Economic Structures*, 7(1), 15. doi: <https://doi.org/10.1186/s40008-018-0115-1>

1 Introduction

[Wiedmann \(2017\)](#) established a method to decompose total impact multipliers (TIMs) in a supply-and-use table (SUT) framework so that impacts originating from industries and from products can be distinguished. In the SUT framework, the use table displays the products bought by industries and the supply table presents the products made by industries in monetary terms ([Eurostat 2008](#)). A symmetric input-output table (SIOT) converts SUTs into one single matrix that can either be a product-by-product or industry-by-industry framework. Hence, the SUT framework has the advantage of portraying differentiated industries and products, which makes possible the allocation of several products (such as co-products and by-products) to any one industry. The usefulness of this approach is enhanced if the product level detail in the SUT is higher than the number of industry sectors. This is the case if additional original data from statistical offices are available or if additional information (e.g. specific process data) is used to disaggregate product sectors.

Hybrid life cycle assessment (hLCA) combines the comprehensiveness of input-output analysis (IOA) and the specificity of life cycle assessment (LCA) to perform environmental and sustainability analyses ([Crawford et al. 2018](#); [Kitzes 2013](#); [Miller and Blair 2009](#); [Nakamura and Nansai 2016](#)). For hLCA methods such as the integrated hLCA and mixed-unit hLCA, the input-output table (IOT) is augmented to include an additional life cycle inventory (LCI) process matrix ([Suh 2004](#); [Suh and Huppel 2000](#)). Process data are concatenated via the downstream cut-off (C^d) matrix to a SIOT or a SUT, and it is therefore desirable to be able to trace impacts originating from these processes. When the C^d matrix is employed in the integrated hybrid LCA, the results are presented as an expanded LCI for a specific product or process of impact in physical units. Integrated hLCA developed by [Suh \(2004\)](#) have been utilised and applied in previous research, including [Bush et al. \(2014\)](#), [Crawford et al. \(2018\)](#), [Hawkins et al. \(2007\)](#), [Hawkins \(2007\)](#), [Ibn-Mohammed et al. \(2016\)](#), [Wiedmann et al. \(2011\)](#) but none of them have shown the explicit contribution of processes to the total hybrid LCIs.

In this note, the TIMs decomposition by industry and product method developed by [Wiedmann \(2017\)](#) is further adapted to allow the decomposition of LCIs by *origin* or *final-stage inputs*, in an integrated (or mixed-unit) hLCA-SUT framework. These two types of decomposition are best illustrated with an example. Cement is used as a final-stage input to produce concrete. A typical LCA question is how much impact (e.g. greenhouse gas emissions (GHGE)) does cement contribute to the total LCI of concrete.

Please cite the published version of this paper:

Teh, S.H., Wiedmann, T., (2018) Decomposition of integrated hybrid life cycle inventories by origin and final-stage inputs. *Journal of Economic Structures*, 7(1), 15. doi: <https://doi.org/10.1186/s40008-018-0115-1>

The LCI decomposition by *final-stage inputs* allocates embodied impacts of processes and products (as well as direct industry impacts) that are directly used in the final-stage inputs in the making of a product. For example, LCI impacts by *final-stage inputs* include products and processes (e.g. recycled concrete aggregate, transport, cement, electricity, and sand) that supply directly to the last stage of inputs of cement production to produce one unit of concrete (Figure 1). Decomposition of LCI by *final-stage inputs* is the novel contribution of this note.

The LCI decomposition by *origin* assigns economy-wide impacts of an industry (and process) as the ultimate origin of emissions in the making of a product. For example, the ultimate origin of concrete production arises from system-wide impacts of the cement production process. This can originate from any industry and process at any stage of the supply chain (e.g. electricity and transport) that uses cement in the life cycle of concrete (Figure 2).

An example application using concrete as a case study will be presented to compare results from the two types of decomposition. An Excel and MATLAB worked example is included in the Supplementary Information (SI), with some of the figures from the Excel sheet presented here.

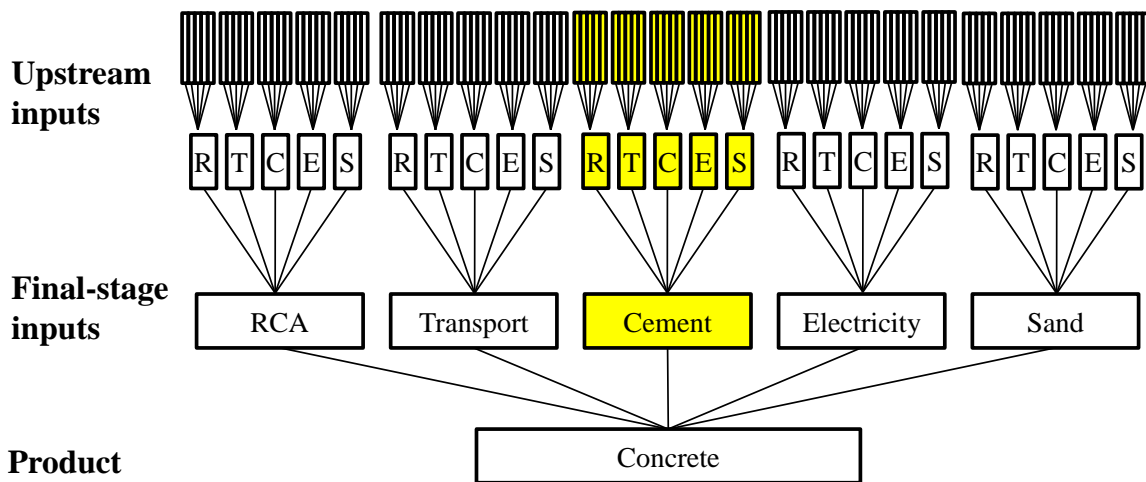

Figure 1: LCI decomposition by *final-stage inputs*, using cement as an example for a product that is used in the final-stage of producing the product for which an LCI is undertaken.

Please cite the published version of this paper:

Teh, S.H., Wiedmann, T., (2018) Decomposition of integrated hybrid life cycle inventories by origin and final-stage inputs. *Journal of Economic Structures*, 7(1), 15. doi: <https://doi.org/10.1186/s40008-018-0115-1>

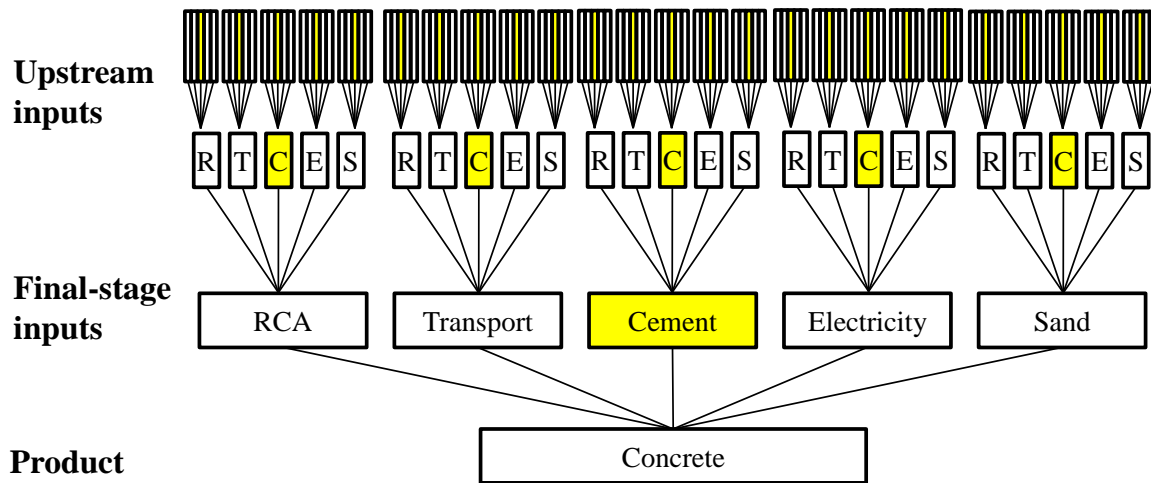

Figure 2: LCI decomposition by *origin*, using the process of producing cement as an example for the ultimate origin of impacts from one particular process.

2 Method

2.1 Integrated hybrid life cycle assessment

Integrated hLCA integrates an input-output (IO) data with a full set of LCI process matrix through the upstream cut-off (C^u) and C^d matrix (Figure 3) (Suh 2004, 2006). The IO data which can be in SIOT or SUT format will be referred to as the “IO system”, and the LCI process matrix as the “process system”. For the sake of generalisation, the following exposition is based on the SUT format for IO data (from which SIOT can be derived using standard techniques; (Miller and Blair 2009, Chapter 4; Rueda-Cantuche and Raa 2007; Rueda-Cantuche and Raa 2009)).

The process system is derived from a LCI database and describes the inputs needed to produce a functional unit of product or process in physical units (pu). A process is defined as an activity that produces a functional unit that can be either a product or process (Suh 2004). The standard procedure of converting the LCI database to the process coefficient matrix (A_p) involves normalising the LCI database to adjust the inputs needed to produce one functional unit of output (Heijungs and Suh 2006; Suh 2004; Wiedmann et al. 2011). The same step is repeated for the associated impact satellite data to produce the impact-by-process vector (f_p) that reflects the total direct impacts associated to produce one functional unit of output. The resultant normalised functional unit of outputs will appear as 1’s on the diagonal of the process system, and the remaining entries of the process system representing inputs are further adjusted to be reflected as negative values in order to capture the flow direction of both outputs and inputs (Suh 2004).

Please cite the published version of this paper:

Teh, S.H., Wiedmann, T., (2018) Decomposition of integrated hybrid life cycle inventories by origin and final-stage inputs. Journal of Economic Structures, 7(1), 15. doi: <https://doi.org/10.1186/s40008-018-0115-1>

The IO system consists of a transaction table (**T** matrix) that is usually published every alternate year by national statistical offices. The **T** matrix captures trades between all the industry sectors in a national economy in a given year in monetary units (mu). The IO system is prepared by deducting the technology coefficient matrix (**A**_{IO}) by the identity matrix (**I**), where **A**_{IO} is calculated by dividing each transaction (x_{ij}) in the **T** matrix by the total industry output (X_j). The impact satellite data-by-industry vector is divided by total industry output to produce the DIMs vector (**f**_{IO}) to represent the total direct impact of an industry in pu per mu (e.g. kg of CO₂-eq per dollar) ([Kitzes 2013](#); [Miller and Blair 2009](#)).

The **C**^u matrix complements the process system by adding any absent higher upstream monetary input data from IO flows to the process system. The **C**^d matrix (if present) captures the physical amount of products produced by the processes that flows into the IO system. Figure 3 presents a full framework of the (**I-A**_{IH}) coefficient matrix of integrated hLCA consisting of the (**I-A**_p), **C**^u, **C**^d, (**I-A**_{IO}) coefficient matrices and the associated process and IO impact coefficients (**f**_p and **f**_{IO}).

The number of rows and columns are represented by q , l , m , n in Figure 3 and are used in equations in Section 2.2:

q = the number of row(s) of environmental accounts/extensions ($q=1$ in this example);

l = the number of rows/columns in the process system ($l=8$ in this example);

m = the number of rows/columns of industry sectors in the IO system in the SUT format ($m=3$ in this example);

n = the number of rows/columns of product sectors in the IO system in the SUT format ($n=5$ in this example).

Please cite the published version of this paper:

Teh, S.H., Wiedmann, T., (2018) Decomposition of integrated hybrid life cycle inventories by origin and final-stage inputs. Journal of Economic Structures, 7(1), 15. doi: <https://doi.org/10.1186/s40008-018-0115-1>

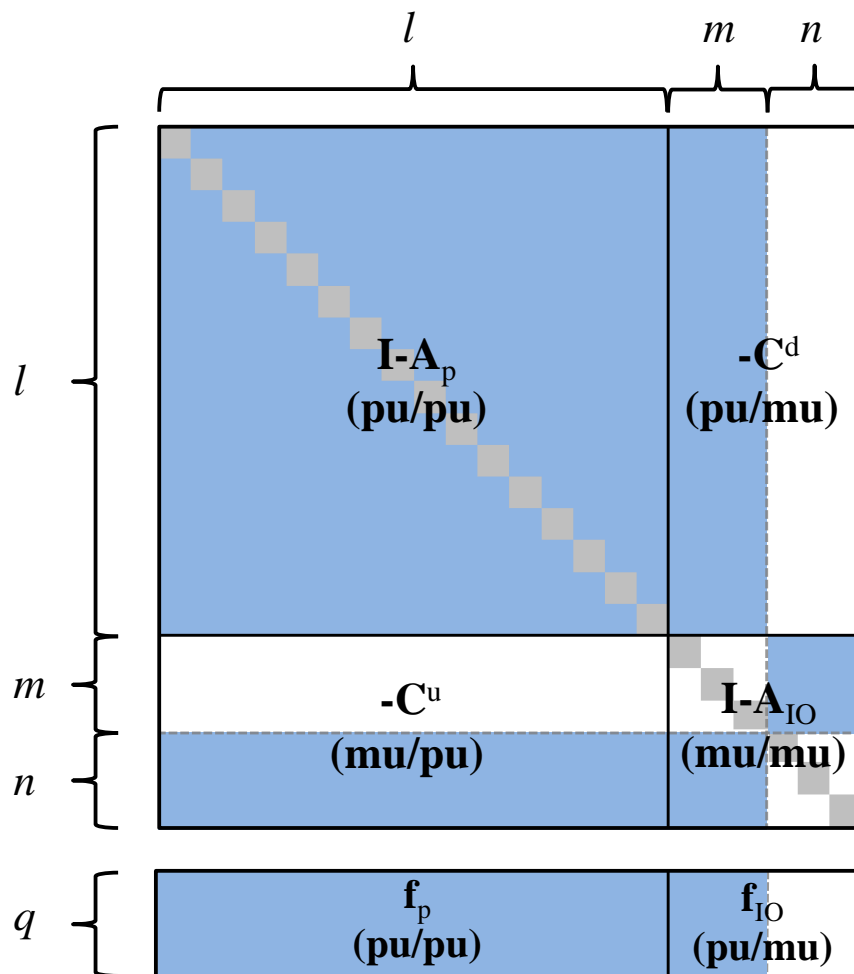

Figure 3: Integrated coefficient matrix $(I-A_{IH})$ of integrated hybrid LCA (blue shaded areas include non-zero values but may be sparsely populated; non-shaded areas contain zeroes; grey shaded areas represent 1's on the diagonal; pu= physical units; mu= monetary units)

Please cite the published version of this paper:

Teh, S.H., Wiedmann, T., (2018) Decomposition of integrated hybrid life cycle inventories by origin and final-stage inputs. *Journal of Economic Structures*, 7(1), 15. doi: <https://doi.org/10.1186/s40008-018-0115-1>

2.2 Decomposition of integrated hybrid life cycle inventories

2.2.1 Integrated hybrid LCIs

Integrated hybrid LCIs (\mathbf{m}_{IH}) are derived from the well-known Leontief demand-pull calculus (Leontief 1970). The subscript $_{IH}$ indicates that the term includes information from both the IO and process systems. For example, the $(\mathbf{I}-\mathbf{A}_{IH})$ component has been extended to include the process system as well as the downstream and upstream matrices as per Equation 1 (Crawford et al. 2018; Nakamura and Nansai 2016; Suh 2004). For clarity, the $(\mathbf{I}-\mathbf{A}_{IH})$ matrix will be referred to as the integrated coefficient matrix.

$$\mathbf{m}_{IH} = \mathbf{f}_{IH}(\mathbf{I} - \mathbf{A}_{IH})^{-1} = [\mathbf{f}_p \quad \mathbf{f}_{IO}] \begin{bmatrix} \mathbf{I} - \mathbf{A}_p & -\mathbf{C}^d \\ -\mathbf{C}^u & \mathbf{I} - \mathbf{A}_{IO} \end{bmatrix}^{-1} = [\mathbf{m}_p \quad \mathbf{m}_{IO}] \quad \text{Equation 1}$$

Where

\mathbf{m}_{IH} = row vector of integrated hybrid life cycle inventories (results in pu/pu for dimension $1 \times l$) and pu/mu for dimension $1 \times (m+n)$);

\mathbf{f}_p = row vector of process system impact coefficients (measured in pu/pu; dimension: $q \times l$, where $q=1$ in this example);

\mathbf{f}_{IO} = row vector of direct intensity multipliers (DIMs) of the IO system for impacts (measured in pu/mu; dimension: $q \times (m+n)$, where $q=1$ in this example);

$\mathbf{I} - \mathbf{A}_p$ = process coefficient matrix (\mathbf{A}_p) deducted from the normalised functional unit matrix (\mathbf{I}) (measured in pu/pu; dimension: $l \times l$);

$-\mathbf{C}^d$ = downstream cut-off matrix (measured in pu/mu; dimension: $l \times (m+n)$);

$-\mathbf{C}^u$ = upstream cut-off matrix (measured in mu/pu; dimension $(m+n) \times l$);

$\mathbf{I} - \mathbf{A}_{IO}$ = IO technology coefficient matrix (\mathbf{A}_{IO}) deducted from the identity matrix (\mathbf{I}) (measured in mu/mu; dimension: $(m+n) \times (m+n)$);

$\mathbf{I} - \mathbf{A}_{IH}$ = integrated coefficient matrix of dimensions: $(l+m+n) \times (l+m+n)$.

Please cite the published version of this paper:

Teh, S.H., Wiedmann, T., (2018) Decomposition of integrated hybrid life cycle inventories by origin and final-stage inputs. *Journal of Economic Structures*, 7(1), 15. doi: <https://doi.org/10.1186/s40008-018-0115-1>

The general hLCA model satisfies $\mathbf{x} = (\mathbf{I} - \mathbf{A}_{IH})^{-1} \mathbf{y}$, where x and y stand for output and final demand, respectively (Equation 2).

$$\begin{bmatrix} \mathbf{x}_p \\ \mathbf{x}_{IO} \end{bmatrix} = \begin{bmatrix} \mathbf{I} - \mathbf{A}_p & -\mathbf{C}^d \\ -\mathbf{C}^u & \mathbf{I} - \mathbf{A}_{IO} \end{bmatrix}^{-1} \begin{bmatrix} \mathbf{y}_p \\ \mathbf{y}_{IO} \end{bmatrix} \quad \text{Equation 2}$$

From this point forward, \mathbf{C}^u and \mathbf{C}^d are given subscripts to differentiate their matrix state, in order to better understand the decomposition equations. For instance, \mathbf{T} matrix of \mathbf{C}^u and \mathbf{C}^d will be represented by \mathbf{C}_T^u and \mathbf{C}_T^d ; \mathbf{A} matrix of \mathbf{C}^u and \mathbf{C}^d will be represented by \mathbf{C}_A^u and \mathbf{C}_A^d ; and $(\mathbf{I}-\mathbf{A})$ matrix of \mathbf{C}^u and \mathbf{C}^d will be represented by $-\mathbf{C}_A^u$ and $-\mathbf{C}_A^d$ (which is equivalent to $-\mathbf{C}^u$ and $-\mathbf{C}^d$ in literatures as well as in Equation 1 and Equation 2 above).

The mixed-unit coefficient matrix (\mathbf{A}_{IH}) is defined here for readability and application in Equation 5 and Equation 6. \mathbf{A}_{IH} (Peters and Hertwich 2006) is calculated by deducting the integrated coefficient matrix ($\mathbf{I}-\mathbf{A}_{IH}$) from the identity matrix (\mathbf{I}) as shown in Equation 3.

$$\mathbf{A}_{IH} = \mathbf{I} - (\mathbf{I} - \mathbf{A}_{IH}) = \mathbf{I} - \begin{bmatrix} \mathbf{I} - \mathbf{A}_p & -\mathbf{C}_A^d \\ -\mathbf{C}_A^u & \mathbf{I} - \mathbf{A}_{IO} \end{bmatrix} = \begin{bmatrix} \mathbf{A}_p & \mathbf{C}_A^d \\ \mathbf{C}_A^u & \mathbf{A}_{IO} \end{bmatrix} \quad \text{Equation 3}$$

Please cite the published version of this paper:

Teh, S.H., Wiedmann, T., (2018) Decomposition of integrated hybrid life cycle inventories by origin and final-stage inputs. *Journal of Economic Structures*, 7(1), 15. doi: <https://doi.org/10.1186/s40008-018-0115-1>

2.2.2 Decomposition of LCIs by origin

A decomposition of LCIs by *origin* is calculated with Equation 4 (one impact at a time, because impact coefficient vectors have been diagonalised). The decomposed values reveal the ultimate origin of impacts from either industries or processes. The superscript $\hat{\cdot}$ indicates the diagonalisation of the DIMs vector. Figure 4 presents an example transaction matrix utilising a SUT framework for the IO system with environmental extensions vector.

$$\mathbf{M}^{ori} = \hat{\mathbf{f}}_{IH}(\mathbf{I} - \mathbf{A}_{IH})^{-1} = \begin{bmatrix} \hat{\mathbf{f}}_p & \mathbf{0} \\ \mathbf{0} & \hat{\mathbf{f}}_{IO} \end{bmatrix} \begin{bmatrix} \mathbf{I} - \mathbf{A}_p & -\mathbf{C}_A^d \\ -\mathbf{C}_A^u & \mathbf{I} - \mathbf{A}_{IO} \end{bmatrix}^{-1} \quad \text{Equation 4}$$

Where

\mathbf{M}^{ori} = matrix of decomposition of LCIs by *origin* (results in a matrix with dimension: $(l+m+n) \times (l+m+n)$, which is measured in pu/pu for dimension $(l+m+n) \times l$ and pu/mu for dimension $(l+m+n) \times (m+n)$);

$\hat{\mathbf{f}}_p$ = diagonalised vector of process system impact coefficients (measured in pu/pu; dimension: $l \times l$);

$\hat{\mathbf{f}}_{IO}$ = diagonalised vector of DIMs of the IO system for impacts (measured in pu/mu; dimension: $(m+n) \times (m+n)$);

$\mathbf{I} - \mathbf{A}_p$ = process coefficient matrix (\mathbf{A}_p) deducted from the normalised functional unit matrix (\mathbf{I}) (measured in pu/pu; dimension: $l \times l$);

$-\mathbf{C}_A^d$ = downstream cut-off coefficient matrix (measured in pu/mu; dimension: $l \times (m+n)$);

$-\mathbf{C}_A^u$ = upstream cut-off coefficient matrix (measured in mu/pu; dimension $(m+n) \times l$);

$\mathbf{I} - \mathbf{A}_{IO}$ = IO technology coefficient matrix (\mathbf{A}_{IO}) deducted from the identity matrix (\mathbf{I}) (measured in mu/mu; dimension: $(m+n) \times (m+n)$).

The resulting LCI decomposition answers “where do emissions ultimately come from?”. For example, 0.018 kg of CO₂ of life-cycle emissions originates from Industry A to produce a unit (\$) of Product 4 (Figure 5). This includes the direct contribution from Industry A to produce Product 4, and also the contribution from any supply chain step in the making of Product 4. The same holds true for processes. For example, electricity (Industry B, Product 2) is used to produce concrete (Product 4). The 0.131 kg/\$ of life-cycle emissions originate directly from the electricity industry itself as well as electricity used by any other upstream suppliers (e.g. cement, sand, transport, etc.), from any production layer of the supply chain.

Please cite the published version of this paper:

Teh, S.H., Wiedmann, T., (2018) Decomposition of integrated hybrid life cycle inventories by origin and final-stage inputs. Journal of Economic Structures, 7(1), 15. doi: <https://doi.org/10.1186/s40008-018-0115-1>

	Proc 1	Proc 2	Proc 3	Proc 4	Proc 5	Proc 6	Proc 7	Proc 8	Ind A	Ind B	Ind C	Prod 1	Prod 2	Prod 3	Prod 4	Prod 5	Final demand (FD)	Total output (X)
Proc 1	-	0.40	0.10	0.04	0.01	0.10	0.20	0.10	1.50	1.50	1.55	-	-	-	-	-	-	5.50
Proc 2	0.20	-	0.10	0.10	0.02	0.10	0.20	0.04	2.00	2.08	2.00	-	-	-	-	-	-	6.84
Proc 3	0.10	0.40	-	0.10	0.02	0.10	0.20	0.03	1.50	1.02	1.50	-	-	-	-	-	-	4.97
Proc 4	0.20	0.30	0.01	-	0.60	0.10	0.10	0.03	1.20	1.30	1.30	-	-	-	-	-	-	5.14
Proc 5	0.05	0.20	0.01	0.30	-	0.20	0.10	0.05	2.00	1.50	2.09	-	-	-	-	-	-	6.50
Proc 6	0.10	0.01	0.07	0.03	0.30	-	0.10	0.05	1.50	2.50	2.54	-	-	-	-	-	-	7.20
Proc 7	0.30	0.02	0.10	0.03	0.04	0.30	-	0.07	2.00	2.60	2.04	-	-	-	-	-	-	7.50
Proc 8	0.05	0.01	0.08	0.04	0.01	0.30	0.10	-	1.50	1.78	1.50	-	-	-	-	-	-	5.37
Ind A	-	-	-	-	-	-	-	-	-	-	-	228.00	242.50	100.00	-	-	110	680.50
Ind B	-	-	-	-	-	-	-	-	-	-	-	-	-	252.50	270.50	140	663.00	
Ind C	-	-	-	-	-	-	-	-	-	-	-	-	-	1,000.00	1,588.50	180	2,768.50	
Prod 1	1.00	0.50	0.50	0.50	1.00	2.00	1.50	1.00	35.00	55.00	20.00	-	-	-	-	-	110	228.00
Prod 2	0.50	1.00	2.00	1.00	1.00	0.50	0.50	1.00	35.00	25.00	30.00	-	-	-	-	-	145	242.50
Prod 3	0.50	1.00	1.00	0.50	1.50	0.50	1.50	1.00	10.00	50.00	50.00	-	-	-	-	-	235	352.50
Prod 4	1.50	0.50	0.50	2.00	0.50	2.00	2.00	1.50	10.00	200.00	100.00	-	-	-	-	-	950	1,270.50
Prod 5	1.00	2.50	0.50	0.50	1.50	1.00	1.00	0.50	20.00	200.00	200.00	-	-	-	-	-	1,160	1,588.50
Value added	-	-	-	-	-	-	-	-	557.30	118.72	2,353.98	-	-	-	-	-	-	-
Total input (X')	5.50	6.84	4.97	5.14	6.50	7.20	7.50	5.37	680.50	663.00	2,768.50	228.00	242.50	352.50	1,270.50	1,588.50	-	-
Direct emissions (CO ₂) (F)	10	20	15	10	30	30	22	24	100	300	300	-	-	-	-	-	-	-
DIMs (f _{HH} = F / X)	1.818	2.924	3.018	1.946	4.615	4.167	2.933	4.469	0.147	0.452	0.108	-	-	-	-	-	-	-
Units	kg/kg	kg/kg	kg/kg	kg/kg	kg/kg	kg/kg	kg/kg	kg/kg	kg/\$	kg/\$	kg/\$	-	-	-	-	-	-	-

Figure 4: Example transaction matrix with eight processes, three industries and five product sectors with extensions for greenhouse gas emissions (upstream and downstream cut-off matrices are shaded in green and orange, respectively).

Please cite the published version of this paper:

Teh, S.H., Wiedmann, T., (2018) Decomposition of integrated hybrid life cycle inventories by origin and final-stage inputs. *Journal of Economic Structures*, 7(1), 15. doi: <https://doi.org/10.1186/s40008-018-0115-1>

Units	Total m_{Hy} (Total LCIs)																
	Proc 1	Proc 2	Proc 3	Proc 4	Proc 5	Proc 6	Proc 7	Proc 8	Ind A	Ind B	Ind C	Prod 1	Prod 2	Prod 3	Prod 4	Prod 5	
kg/kg	3.767	2.776	1.169	1.238	1.646	2.189	2.177	0.941	0.046	0.067	0.015	0.046	0.046	0.850	1.393	0.622	0.355
kg/kg	3.271	6.131	1.678	1.944	2.492	3.161	3.149	1.239	0.068	0.099	0.022	0.068	0.068	0.068	0.091	0.038	0.022
kg/kg	3.690	4.848	4.749	2.340	2.988	3.774	3.769	1.441	0.079	0.113	0.025	0.079	0.079	0.079	0.104	0.044	0.025
kg/kg	3.387	4.123	1.553	4.097	3.836	3.464	3.135	1.315	0.071	0.103	0.023	0.071	0.071	0.071	0.094	0.040	0.023
kg/kg	5.631	7.035	2.722	4.741	9.992	6.469	5.530	2.383	0.131	0.187	0.042	0.131	0.131	0.131	0.171	0.073	0.042
kg/kg	3.753	4.112	1.975	2.505	4.255	7.888	3.657	1.608	0.085	0.131	0.029	0.085	0.085	0.085	0.118	0.051	0.029
kg/kg	3.554	3.412	1.745	1.844	2.665	3.754	5.691	1.377	0.071	0.106	0.023	0.071	0.071	0.071	0.096	0.041	0.023
kg/kg	3.146	3.393	1.850	2.024	2.895	4.342	3.227	5.685	0.075	0.113	0.024	0.075	0.075	0.075	0.102	0.043	0.024
Ind A	0.663	0.769	0.405	0.454	0.627	0.721	0.651	0.324	0.179	0.049	0.009	0.179	0.179	0.179	0.086	0.018	0.009
Ind B	0.886	1.021	0.504	0.614	0.846	0.946	0.891	0.437	0.026	0.548	0.018	0.026	0.026	0.026	0.400	0.131	0.018
Ind C	0.575	0.663	0.300	0.394	0.528	0.607	0.555	0.265	0.018	0.092	0.126	0.018	0.018	0.018	0.071	0.119	0.126
Prod 1	-	-	-	-	-	-	-	-	-	-	-	-	-	-	-	-	-
Prod 2	-	-	-	-	-	-	-	-	-	-	-	-	-	-	-	-	-
Prod 3	-	-	-	-	-	-	-	-	-	-	-	-	-	-	-	-	-
Prod 4	-	-	-	-	-	-	-	-	-	-	-	-	-	-	-	-	-
Prod 5	-	-	-	-	-	-	-	-	-	-	-	-	-	-	-	-	-

(columns add up to total LCIs)

Figure 5: Example decomposition of life cycle inventories by *origin* (industry or process).

Please cite the published version of this paper:

Teh, S.H., Wiedmann, T., (2018) Decomposition of integrated hybrid life cycle inventories by origin and final-stage inputs. *Journal of Economic Structures*, 7(1), 15. doi: <https://doi.org/10.1186/s40008-018-0115-1>

2.2.3 Decomposition of LCIs by final-stage inputs

To calculate the decomposition of integrated hybrid LCIs by the contributions from *final-stage inputs*, Equation (8) from [Wiedmann \(2017\)](#) is now adjusted to match the integrated hLCA framework. This decomposition follows the same principle as [Wiedmann \(2017\)](#). \mathbf{M}^{ifsi} is the intermediate step matrix when decomposing LCIs by *final-stage inputs*.

$$\mathbf{M}^{ifsi} = \hat{\mathbf{f}}_{IH} + \hat{\mathbf{m}}_{IH} \cdot \mathbf{A}_{IH} \quad \text{Equation 5}$$

Where,

\mathbf{M}^{ifsi} = intermediate step (i) matrix when decomposing LCIs by *final-stage inputs (fsi)* (results in a matrix with dimension: $(l+m+n) \times (l+m+n)$).

As explained in [Wiedmann \(2017\)](#), the final-stage of inputs needed by an industry or process is expressed in the elements of the mixed-unit coefficient matrix (\mathbf{A}_{IH}) (Equation 3) ([Peters and Hertwich 2006](#)). Equation 6 (rewritten from Equation 5) shows the reworked formula to calculate the decomposition of LCIs by *final-stage inputs*. LCIs of the process (\mathbf{m}_p) and IO (\mathbf{m}_{IO}) systems are diagonalised in this equation, which is the same as the diagonalisation of row vector \mathbf{m}_{IH} from Equation 1.

$$\mathbf{M}^{ifsi} = \begin{bmatrix} \hat{\mathbf{f}}_p & \mathbf{0} \\ \mathbf{0} & \hat{\mathbf{f}}_{IO} \end{bmatrix} + \begin{bmatrix} \hat{\mathbf{m}}_p & \mathbf{0} \\ \mathbf{0} & \hat{\mathbf{m}}_{IO} \end{bmatrix} \begin{bmatrix} \mathbf{A}_p & \mathbf{C}_A^d \\ \mathbf{C}_A^u & \mathbf{A}_{IO} \end{bmatrix} \quad \text{Equation 6}$$

In the intermediate step in decomposition of LCIs by final-stage (\mathbf{M}^{ifsi}) (Figure 6), $\hat{\mathbf{f}}_{IH}$ represents the direct impacts from processes or industries (also known as scope 1 emissions for the latter in terms of GHGEs), and $\hat{\mathbf{m}}_{IH} \cdot \mathbf{A}_{IH}$ represents the life-cycle impacts from final-stage inputs, which takes place outside of the industry ([Wiedmann 2009, 2017](#)).

The calculation of \mathbf{M}^{ifsi} shows product LCIs stemming from industries, but does not show impacts stemming from products and processes (Figure 6). Scaling the decomposition of industry LCIs ($\mathbf{M}_{1:(l+m+n),1:l+m}^{ifsi}$) using the technology coefficients of processes and industries ($\mathbf{a}_{1:l+m,k}$) will distinguish impacts from products and processes. The scaling procedure results in displaying the contribution of all processes and industries to the production of products. This is done through Equation 7 and Equation 8.

Please cite the published version of this paper:

Teh, S.H., Wiedmann, T., (2018) Decomposition of integrated hybrid life cycle inventories by origin and final-stage inputs. *Journal of Economic Structures*, 7(1), 15. doi: <https://doi.org/10.1186/s40008-018-0115-1>

The \mathbf{A}_{IH} matrix has a dimension of $(l+m+n) \times (l+m+n)$. Here, the product k column from all process and industry $(l+m)$ rows is extracted from the product (n) columns in the \mathbf{A}_{IH} matrix and is transposed (represented with symbol $'$). The transposed $(\mathbf{a}_{1:l+m,k})$ is multiplied with the intermediate decomposition results (\mathbf{M}^{ifsi}) from Equation 6, consisting of all rows and columns with the exception of product (n) columns. This procedure is summarised as Equation 7, and results in \mathbf{S}_k^{fsi} that represents a scaled matrix specifically for product k . Note that Equation 7 is a row-wise multiplication (represented by the symbol (\times)) of the transposed $(\mathbf{a}_{1:l+m,k})$ with LCI columns of processes and industries, $\mathbf{M}_{1:(l+m+n),1:l+m}^{ifsi}$.

$$\mathbf{S}_k^{fsi} = (\mathbf{a}_{1:l+m,k})' \times \mathbf{M}_{1:(l+m+n),1:l+m}^{ifsi} \quad \text{Equation 7}$$

Where,

\mathbf{S}_k^{fsi} = scaled matrix specifically for product k (results in a matrix with dimension: $(l+m+n) \times (l+m)$).

The results show new columns of decomposed industry LCIs that are adjusted by the technology coefficient composition of industries involved in the making of product k .

$$\mathbf{m}_k^{fsi} = \mathbf{S}_k^{fsi} \cdot \mathbf{1}_{l+m+n,1} \quad \text{Equation 8}$$

Where,

\mathbf{m}_k^{fsi} = product k 's column of LCIs decomposed by *final-stage inputs* (results in a vector with dimension: $(l+m+n) \times 1$), which will be placed in the column k of the final matrix \mathbf{M}^{fsi} ;

\mathbf{M}^{fsi} = final matrix when decomposing LCIs by *final-stage inputs (fsi)* (results in a matrix with dimension: $(l+m+n) \times n$; measured in pu/mu).

Equation 8 represents the row summation of matrix \mathbf{S}_k^{fsi} , achieved via multiplication with a column **vector of ones** of $l+m+n$ rows to produce a new column vector, which represents LCIs decomposed for k product and process (\mathbf{m}_k^{fsi}).

Please cite the published version of this paper:

Teh, S.H., Wiedmann, T., (2018) Decomposition of integrated hybrid life cycle inventories by origin and final-stage inputs. Journal of Economic Structures, 7(1), 15. doi: <https://doi.org/10.1186/s40008-018-0115-1>

The calculation steps shown in Equation 7 and Equation 8 are repeated for the n number of products in the IO system to produce a complete decomposition of product LCIs by *final-stage inputs*, and this final outcome is represented by the matrix \mathbf{M}^{fsi} (Figure 7). The columns in the matrix \mathbf{M}^{fsi} comprise impacts from l rows of processes, m rows of industries and n rows of products. The impacts from industries (m rows) represent the direct impacts from sources that are owned or controlled by industries to manufacture a product, whilst the indirect impacts from processes and products (l and n rows) are upstream impacts covering life cycle stages from cradle-to-final stage input to produce a product.

The resulting LCI decomposition answers questions like how much life-cycle impacts stem from the final-stage inputs (products, processes or direct industry impacts) in the making of a product. Following the same example of electricity as Industry B to produce concrete as Product 4, 0.096 kg/\$ originates from the electricity industry (Industry B) itself to produce electricity for the direct production process, whilst all other contributions are life-cycle emissions of processes or products used, embodying impacts from upstream cement, transport, sand, electricity, etc. For example, the 0.014 kg/\$ for Product 2 (electricity) includes upstream emissions of producing the electricity for the production process of Product 4 (Figure 7).

Please cite the published version of this paper:

Teh, S.H., Wiedmann, T., (2018) Decomposition of integrated hybrid life cycle inventories by origin and final-stage inputs. Journal of Economic Structures, 7(1), 15. doi: <https://doi.org/10.1186/s40008-018-0115-1>

Total LCIs (Total m_{H_i})		32.322	38.283	18.651	22.196	32.769	37.314	32.432	17.015	0.850	1.608	0.355	0.850	0.850	1.393	0.622	0.355
Units		kg/kg	kg/kg	kg/kg	kg/kg	kg/kg	kg/kg	kg/kg	kg/kg	kg/\$	kg/\$	kg/\$	kg/\$	kg/\$	kg/\$	kg/\$	kg/\$
		Proc 1	Proc 2	Proc 3	Proc 4	Proc 5	Proc 6	Proc 7	Proc 8	Ind A	Ind B	Ind C	Prod 1	Prod 2	Prod 3	Prod 4	Prod 5
Proc 1		1.818	12.929	3.232	1.293	0.323	3.232	6.464	3.232	0.071	0.073	0.018	-	-	-	-	-
Proc 2		7.657	2.924	3.828	3.828	0.766	3.828	7.657	1.531	0.113	0.120	0.028	-	-	-	-	-
Proc 3		1.865	7.460	3.018	1.865	0.373	1.865	3.730	0.560	0.041	0.029	0.010	-	-	-	-	-
Proc 4		4.439	6.659	0.222	1.946	13.317	2.220	2.220	0.666	0.039	0.044	0.010	-	-	-	-	-
Proc 5		1.638	6.554	0.328	9.831	4.615	6.554	3.277	1.638	0.096	0.074	0.025	-	-	-	-	-
Proc 6		3.731	0.373	2.612	1.119	11.194	4.167	3.731	1.866	0.082	0.141	0.034	-	-	-	-	-
Proc 7		9.730	0.649	3.243	0.973	1.297	9.730	2.933	2.270	0.095	0.127	0.024	-	-	-	-	-
Proc 8		0.851	0.170	1.361	0.681	0.170	5.105	1.702	4.469	0.038	0.046	0.009	-	-	-	-	-
Ind A		-	-	-	-	-	-	-	-	0.147	-	-	0.850	0.850	0.241	-	-
Ind B		-	-	-	-	-	-	-	-	-	0.452	-	-	-	1.152	0.342	-
Ind C		-	-	-	-	-	-	-	-	-	-	0.108	-	-	-	0.280	0.355
Prod 1		0.155	0.062	0.085	0.083	0.131	0.236	0.170	0.158	0.044	0.070	0.006	-	-	-	-	-
Prod 2		0.077	0.124	0.342	0.165	0.131	0.059	0.057	0.158	0.044	0.032	0.009	-	-	-	-	-
Prod 3		0.127	0.204	0.280	0.136	0.321	0.097	0.279	0.259	0.020	0.105	0.025	-	-	-	-	-
Prod 4		0.170	0.045	0.063	0.242	0.048	0.173	0.166	0.174	0.009	0.188	0.022	-	-	-	-	-
Prod 5		0.065	0.130	0.036	0.035	0.082	0.049	0.047	0.033	0.010	0.107	0.026	-	-	-	-	-

(columns add up to total LCIs)

Figure 6: Intermediate step in the decomposition of LCIs by *final-stage inputs*. Impacts from processes, products and industries are identified but not yet allocated to products.

Please cite the published version of this paper:

Teh, S.H., Wiedmann, T., (2018) Decomposition of integrated hybrid life cycle inventories by origin and final-stage inputs. *Journal of Economic Structures*, 7(1), 15. doi: <https://doi.org/10.1186/s40008-018-0115-1>

Total m_{IH} (Total LCIs)	0.850	0.850	1.393	0.622	0.355	kg/\$
Check with above:	0.850	0.850	1.393	0.622	0.355	kg/\$
	Prod 1	Prod 2	Prod 3	Prod 4	Prod 5	
Proc 1	0.071	0.071	0.073	0.030	0.018	kg/\$
Proc 2	0.113	0.113	0.118	0.047	0.028	kg/\$
Proc 3	0.041	0.041	0.032	0.014	0.010	kg/\$
Proc 4	0.039	0.039	0.042	0.017	0.010	kg/\$
Proc 5	0.096	0.096	0.080	0.035	0.025	kg/\$
Proc 6	0.082	0.082	0.124	0.057	0.034	kg/\$
Proc 7	0.095	0.095	0.118	0.046	0.024	kg/\$
Proc 8	0.038	0.038	0.043	0.017	0.009	kg/\$
Ind A	0.147	0.147	0.042	-	-	kg/\$
Ind B	-	-	0.324	0.096	-	kg/\$
Ind C	-	-	-	0.085	0.108	kg/\$
Prod 1	0.044	0.044	0.063	0.020	0.006	kg/\$
Prod 2	0.044	0.044	0.035	0.014	0.009	kg/\$
Prod 3	0.020	0.020	0.081	0.042	0.025	kg/\$
Prod 4	0.009	0.009	0.137	0.058	0.022	kg/\$
Prod 5	0.010	0.010	0.080	0.043	0.026	kg/\$

(columns add up to total LCIs)

Figure 7: Final outcome of decomposition of LCIs by *final-stage inputs*, showing impacts from final stage processes and products and direct final-stage inputs from industries to produce a product.

3 Application

This section presents a case study comparing the LCIs of ordinary Portland cement (OPC) concrete with geopolymers concrete (GPC) using the two decomposition methods. Concrete is chosen as a case study because cement production is responsible for around 5-8% of global GHG emissions (Flower and Sanjayan 2007). Waste and product specific data are usually aggregated or not represented in an IOT. Integration of an LCI with the IOT in the integrated hLCA framework allows specific product or process to be employed in the assessment without entailing disaggregation of the IOT sectors, such as fly ash (FA), ground granulated blast furnace slag (GGBFS), sodium hydroxide (NaOH) and sodium silicate (Na_2SiO_3) and recycled concrete aggregate (RCA).

Based on the same data by Teh et al. (2017), some ingredients of OPC and GPC have been modified to utilise recycling and product specific data from the process system (employed in pu) using the integrated hLCA method. For OPC concrete, RCA is used to replace gravel. For

Please cite the published version of this paper:

Teh, S.H., Wiedmann, T., (2018) Decomposition of integrated hybrid life cycle inventories by origin and final-stage inputs. Journal of Economic Structures, 7(1), 15. doi: <https://doi.org/10.1186/s40008-018-0115-1>

GPC, by-products (FA and GGBFS), specific chemical data (NaOH and Na₂SiO₃) and recycled product data of RCA are used to replace gravel.

The integrated hLCA model consists of a process system utilising data from the Australian Life Cycle Inventory database ([AusLCI 2015](#)), which captures 4463 processes. The IO system is the same two-region SUT framework as utilised in [Teh et al. \(2017\)](#) from the Australian Industrial Ecology Virtual Laboratory (IELab) ([Lenzen et al. 2017](#); [Lenzen et al. 2014](#)), comprising 341 industries and 345 products with a rest-of-the-world (RoW) matrix incorporating 26 sectors. The concrete sector has already been disaggregated to nine different concrete types. The C^d matrix is populated with the same physical process data from Table A.2 in the supplementary information of [Teh et al. \(2017\)](#) for RCA (assuming the same quantity of gravel), FA, GGBFS, NaOH and Na₂SiO₃ for concrete types of “100% OPC 50 MPa concrete” and “90% FA/10% GGBFS Geopolymer 50 MPa concrete”. These physical process data are divided by with the annual sales of functional flow to fill the C^d matrix. The C^u matrix is completely filled following the procedure from [Wiedmann et al. \(2011\)](#). Selected technology coefficients (A_{IO}) of specific industries are allocated to the processes employed in C^d , adjusted via multiplication with the unit price of the processes employed for the C^u matrix. In addition, upstream inputs that are already represented in the process system are removed to avoid double counting. Taking NaOH for an example, the technology coefficient column for “Other basic chemical manufacturing” industry from the IO system is assigned to the “Sodium hydroxide, 50% in H₂O, membrane cell, at plant/RER U/AusSD U” column in the C^u matrix and multiplied with the price of NaOH (0.20 AUD/kg from [McLellan et al. \(2011\)](#)).

Integrated hybrid LCI results are analysed for GPC and OPC using the two decomposition methods (referred to as “by *origin*” and “by *final-stage inputs*” in figures). Results refer to the functional unit of 1 m³ of concrete. Figure 8 shows major emitting industries, products and processes to produce OPC and GPC. Contribution of cement in OPC concrete production is apparent in both decomposition methods. However, cement contribution is higher in the decomposition by *final-stage inputs* method because it represents the indirect emissions embodied in the cement product stemming from all upstream inputs to the final product to produce OPC concrete (shown in Figure 1) whilst by *origin* method captures impacts stemming from all the upstream supply chains to produce OPC concrete (shown in Figure 2).

Impacts from RCA in the OPC concrete could be represented in the decomposition by *final-stage inputs* method (Figure 10), but could not be represented in the by *origin* method (Figure 9). For GPC, decomposition of LCIs by *final-stage inputs* is able to capture process impact granularity by differentiating impacts stemming from RCA, FA, GGBFS, NaOH and Na₂SiO₃, whilst decomposition of LCIs by *origin* is not able to do so. The *final-stage inputs* results enable the identification of life-cycle impacts of specific products such as recycled and by-products to realise if there are environmental benefits in employing them to manufacture a construction material.

Please cite the published version of this paper:

Teh, S.H., Wiedmann, T., (2018) Decomposition of integrated hybrid life cycle inventories by origin and final-stage inputs. *Journal of Economic Structures*, 7(1), 15. doi: <https://doi.org/10.1186/s40008-018-0115-1>

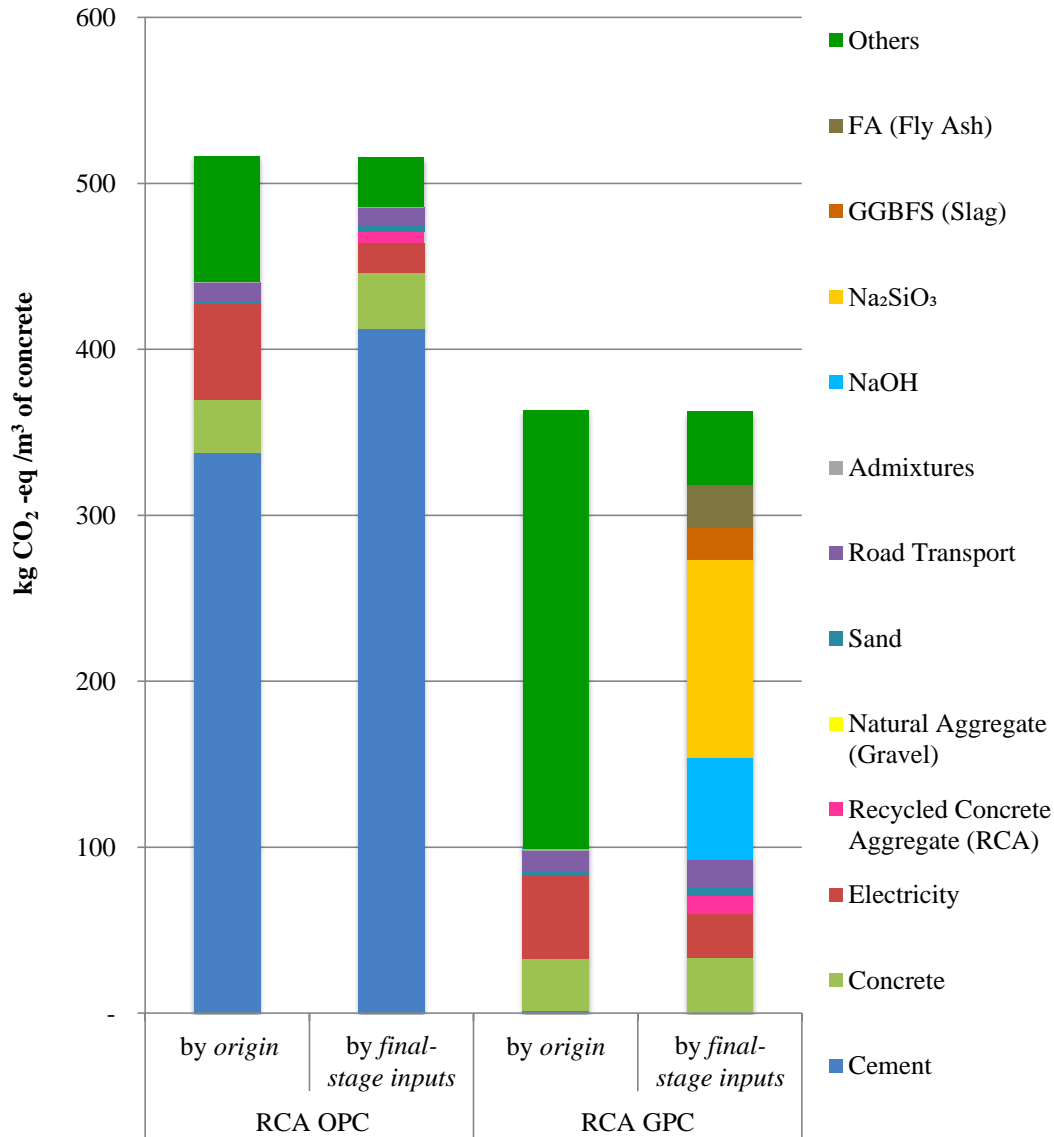

Figure 8: Decomposition of LCIs by *origin* and by *final-stage inputs* for ordinary Portland cement (OPC) concrete and geopolymer concrete (GPC)

Please cite the published version of this paper:

Teh, S.H., Wiedmann, T., (2018) Decomposition of integrated hybrid life cycle inventories by origin and final-stage inputs. *Journal of Economic Structures*, 7(1), 15. doi: <https://doi.org/10.1186/s40008-018-0115-1>

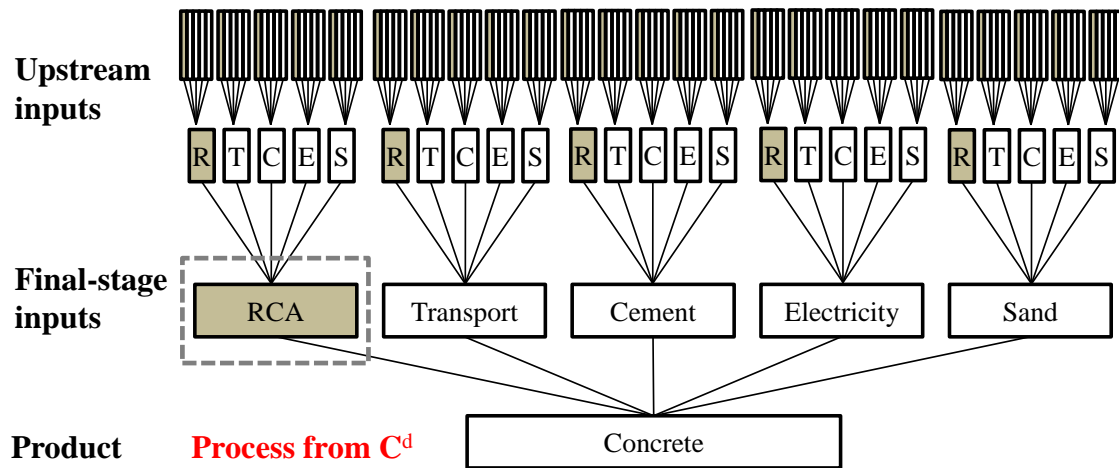

Figure 9: Recycled concrete aggregate (RCA) contribution in the decomposition of LCIs by *origin* method in the OPC concrete production

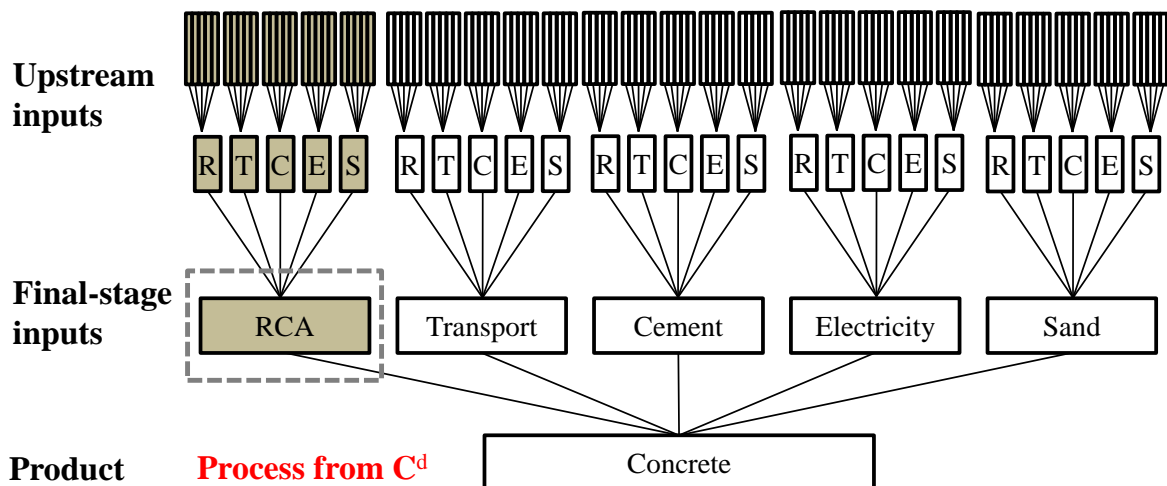

Figure 10: Recycled concrete aggregate (RCA) contribution in the decomposition of LCIs by *final-stage inputs* method in the OPC concrete production

Please cite the published version of this paper:

Teh, S.H., Wiedmann, T., (2018) Decomposition of integrated hybrid life cycle inventories by origin and final-stage inputs. Journal of Economic Structures, 7(1), 15. doi: <https://doi.org/10.1186/s40008-018-0115-1>

4 Conclusion

Results of hybrid LCA are generally discussed in the terms of total impact multipliers (TIMs). The TIMs decomposition by industry and product method developed by [Wiedmann \(2017\)](#) was further advanced to include LCI decomposition by product or process as well. This is useful for the integrated and mixed-unit hybrid LCA method, whereby a complete process LCI system is linked with the IO system through the C^u and C^d matrix. The decomposition of integrated hybrid LCIs by *final-stage inputs* method is able to show life cycle emissions originating from industries, products and processes. It is especially useful when the C^d matrix is used to model specific processes that are aggregated in the IO table ([Suh 2006](#)). For example, specific chemical products such as NaOH and Na₂SiO₃, which are ingredients to produce GPC, are aggregated in the “other basic chemical manufacturing” industry sector in the IO table. The results using the decomposition of integrated hybrid LCIs by industry, product and process are able to show supply chain GHGEs originating from specific processes (e.g. NaOH and Na₂SiO₃) in the production of GPC, thus demonstrating the usefulness of this method. The decomposition method also allows for a direct comparison of results between methods (i.e. comparing results of integrated hLCA with input-output based hLCA or LCA). In conclusion, this method is useful for enriching carbon footprint results by way of a new angle and interpretation, namely to answer the questions “how much life cycle impact is derived from final-stage inputs” (using the “by *final-stage inputs*” method), and “where do emissions ultimately come from” (using the “by *origin*” method).

Please cite the published version of this paper:

Teh, S.H., Wiedmann, T., (2018) Decomposition of integrated hybrid life cycle inventories by origin and final-stage inputs. *Journal of Economic Structures*, 7(1), 15. doi: <https://doi.org/10.1186/s40008-018-0115-1>

5 Appendix

Each entry in \mathbf{C}_A^u (or \mathbf{C}^u) represents the trade in monetary value from a monetary IO sector (\mathbf{C}_T^u) purchased by a physical process sector normalised by the functional unit of the physical process sector (\mathbf{y}_p) (Equation 9). Each entry in \mathbf{C}_A^d (or \mathbf{C}^d) represents the mass in physical value from the physical process sector (\mathbf{C}_T^d) purchased by a monetary IO sector normalised by the total output of the monetary IO sector (\mathbf{X}_{IO}) (Equation 10).

$$\mathbf{C}_A^u = \mathbf{C}_T^u \cdot \hat{\mathbf{y}}_p^{-1} \quad \text{Equation 9}$$

$$\mathbf{C}_A^d = \mathbf{C}_T^d \cdot \hat{\mathbf{X}}_{IO}^{-1} \quad \text{Equation 10}$$

Where

\mathbf{C}_A = upstream (\mathbf{C}^u) and downstream (\mathbf{C}^d) cut-off technology coefficient (\mathbf{A}) matrix (\mathbf{C}_A^u measured in mu/pu, with dimension $(m+n) \times l$; \mathbf{C}_A^d measured in pu/mu with dimension: $l \times (m+n)$);

\mathbf{C}_T = upstream (\mathbf{C}^u) and downstream (\mathbf{C}^d) cut-off transaction (\mathbf{T}) matrix (\mathbf{C}_T^u measured in mu; dimension $(m+n) \times l$; \mathbf{C}_T^d measured in pu; dimension: $l \times (m+n)$);

$\hat{\mathbf{y}}_p$ = diagonalised functional unit of process system, (measured in pu; dimension $l \times l$);

$\hat{\mathbf{X}}_{IO}$ = diagonalised total output of IO system (measured in mu; dimension: $(m+n) \times (m+n)$).

Please cite the published version of this paper:

Teh, S.H., Wiedmann, T., (2018) Decomposition of integrated hybrid life cycle inventories by origin and final-stage inputs. *Journal of Economic Structures*, 7(1), 15. doi: <https://doi.org/10.1186/s40008-018-0115-1>

6 References

- AusLCI (2015) The Australian life cycle inventory database initiative. Australian Life Cycle Assessment Society, Australia. <http://alcas.asn.au/AusLCI/index.php/Datasets/Materials>. Accessed 30.07.15.
- Bush R, Jacques DA, Scott K, Barrett J (2014) The carbon payback of micro-generation: An integrated hybrid input–output approach. *Applied Energy* 119:85-98. doi:10.1016/j.apenergy.2013.12.063.
- Crawford RH, Bontinck P-A, Stephan A, Wiedmann T, Yu M (2018) Hybrid life cycle inventory methods – a review. *J Clean Prod* 172:1273-1288. doi:10.1016/j.jclepro.2017.10.176.
- Eurostat (2008) Eurostat manual of supply, use and input-output tables, 2008 edition. Office for Official Publications of European Communities, Luxembourg. <http://ec.europa.eu/eurostat>. Accessed 15.05.16.
- Flower DM, Sanjayan J (2007) Green house gas emissions due to concrete manufacture. *Int J Life Cycle Assess* 12:282-288. doi:10.1065/lca2007.05.327.
- Hawkins T, Hendrickson C, Higgins C, Matthews HS, Suh S (2007) A mixed-unit input-output model for environmental life-cycle assessment and material flow analysis. *Environ Sci Technol* 41:1024-1031. doi:10.1021/es060871u.
- Hawkins TR (2007) A mixed-unit input-output model for life cycle assessment: Development, uncertainty, and application. Ph.D. Dissertation, Carnegie Mellon University.
- Heijungs R, Suh S (2006) Reformulation of matrix-based LCI: From product balance to process balance. *J Clean Prod* 14:47-51. doi:10.1016/j.jclepro.2005.05.022.
- Ibn-Mohammed T, Koh SCL, Reaney IM, Acquaye A, Wang D, Taylor S, Genovese A (2016) Integrated hybrid life cycle assessment and supply chain environmental profile evaluations of lead-based (lead zirconate titanate) versus lead-free (potassium sodium niobate) piezoelectric ceramics. *Energy Environ Sci* 9:3495-3520. doi:10.1039/C6EE02429G.
- Kitzes J (2013) An introduction to environmentally-extended input-output analysis. *Resources* 2:489-503
- Lenzen M, Geschke A, Malik A, Fry J, Lane J, Wiedmann T, Kenway S, Hoang K, Cadogan-Cowper A (2017) New multi-regional input–output databases for Australia – enabling timely and flexible regional analysis. *Econ Syst Res* 29:275-295. doi:10.1080/09535314.2017.1315331.
- Lenzen M, Geschke A, Wiedmann T, Lane J, Anderson N, Baynes T, Boland J, Daniels P, Dey C, Fry J, Hadjikakou M, Kenway S, Malik A, Moran D, Murray J, Nettleton S, Poruschi L, Reynolds C, Rowley H, Ugon J, Webb D, West J (2014) Compiling and using input–output frameworks through collaborative virtual laboratories. *Sci Total Environ* 485–486:241-251. doi:10.1016/j.scitotenv.2014.03.062.
- Leontief W (1970) Environmental repercussions and the economic structure: An input-output approach. *The review of economics and statistics*:262-271

Please cite the published version of this paper:

Teh, S.H., Wiedmann, T., (2018) Decomposition of integrated hybrid life cycle inventories by origin and final-stage inputs. *Journal of Economic Structures*, 7(1), 15. doi: <https://doi.org/10.1186/s40008-018-0115-1>

McLellan BC, Williams RP, Lay J, van Riessen A, Corder GD (2011) Costs and carbon emissions for geopolymer pastes in comparison to ordinary Portland cement. *J Clean Prod* 19:1080-1090. doi:10.1016/j.jclepro.2011.02.010.

Miller RE, Blair PD (2009) *Input-output analysis: Foundations and extensions*. Cambridge University Press, Cambridge, GBR

Nakamura S, Nansai K (2016) Input–output and hybrid LCA. In: Finkbeiner M (ed) *Special types of life cycle assessment*. Springer Netherlands, Dordrecht, pp 219-291. doi:10.1007/978-94-017-7610-3_6.

Peters GP, Hertwich EG (2006) A comment on “functions, commodities and environmental impacts in an ecological–economic model”. *Ecol Econ* 59:1-6. doi:10.1016/j.ecolecon.2005.08.008.

Rueda-Cantuche JM, Raa TT (2007) Symmetric input-output tables: Products or industries? . Paper presented at the 16th International Input-Output Conference of the International Input-Output Association (IIOA), Istanbul, Turkey, 2-6 July 2007.

Rueda-Cantuche JM, Raa TT (2009) The choice of model in the construction of industry coefficients matrices. *Econ Syst Res* 21:363-376. doi:10.1080/09535310903208344.

Suh S (2004) Functions, commodities and environmental impacts in an ecological–economic model. *Ecol Econ* 48:451-467

Suh S (2006) Reply: Downstream cut-offs in integrated hybrid life-cycle assessment. *Ecol Econ* 59:7-12. doi:10.1016/j.ecolecon.2005.07.036.

Suh S, Huppes G (2000) Gearing input-output model to LCA, part I: General framework for hybrid approach. CML-SSP Working Paper, CML, Leiden University, Leiden, The Netherlands

Teh SH, Wiedmann T, Castel A, de Burgh J (2017) Hybrid life cycle assessment of greenhouse gas emissions from cement, concrete and geopolymer concrete in Australia. *J Clean Prod* 152:312-320. doi:10.1016/j.jclepro.2017.03.122.

Wiedmann T (2009) Editorial: Carbon footprint and input-output analysis- an introduction. *Econ Syst Res* 21:175-186. doi:10.1080/09535310903541256.

Wiedmann T (2017) On the decomposition of total impact multipliers in a supply and use framework. *Economic Structures* 6:11. doi:10.1186/s40008-017-0072-0.

Wiedmann T, Suh S, Feng K, Lenzen M, Acquaye A, Scott K, Barrett JR (2011) Application of hybrid life cycle approaches to emerging energy technologies–the case of wind power in the UK. *Environ Sci Technol* 45:5900-5907